

# C. G. Conn Trumpets

Elkhart, Indiana

1881 – 1942

1881 Catalog image of Trumpet in F/Eb/D

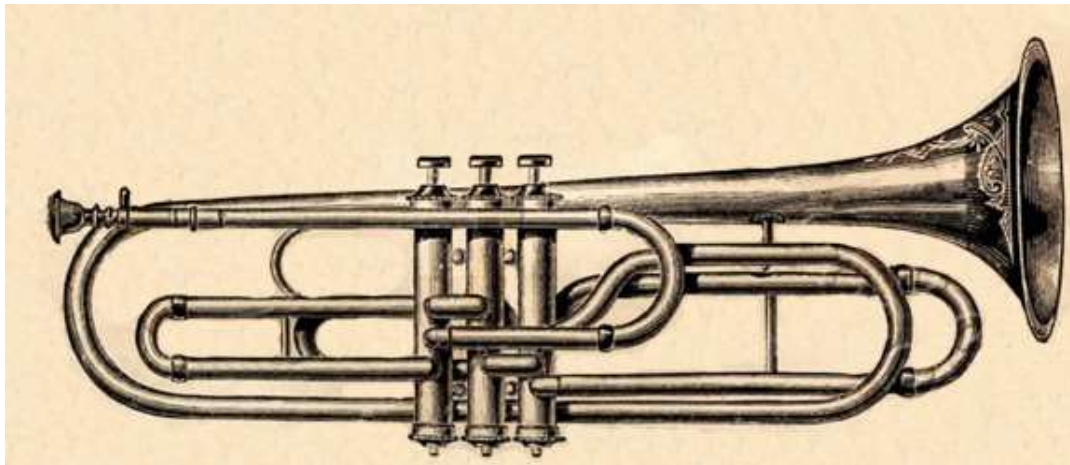

The Perfected New York Wonder Trumpet 1899 – 1905

## The Perfected New York Wonder Trumpet,

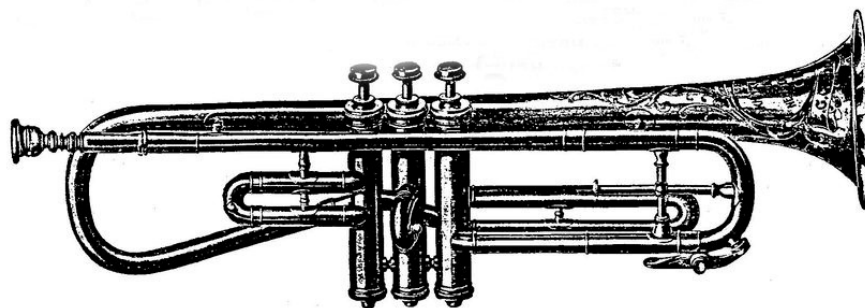

NY Wonder #64289 c.1889 with replacement receiver.



The NY label ends in 1902 - #79046 c.1902 (Metzler Brass)

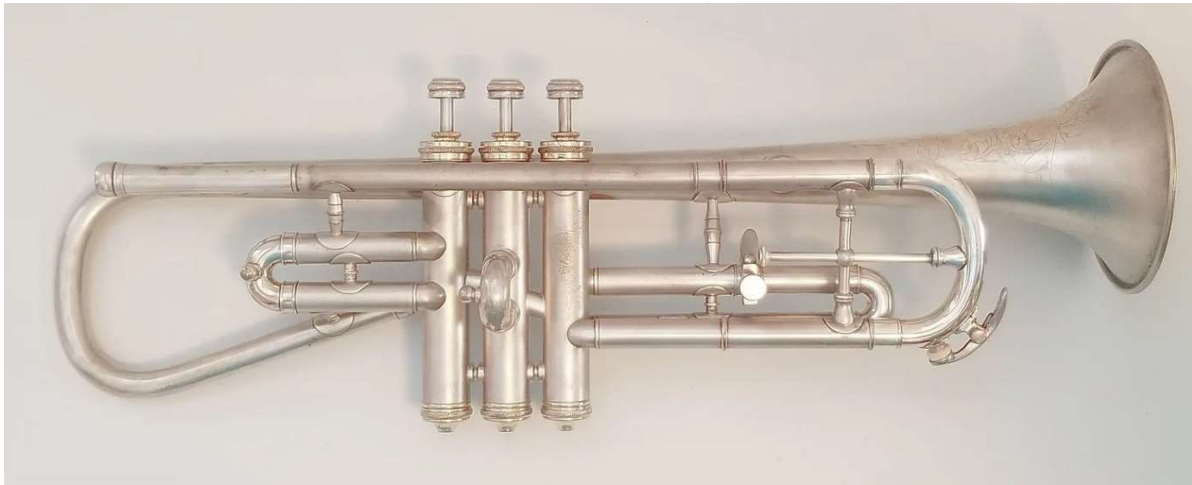

Unchanged design in 1904 Catalog

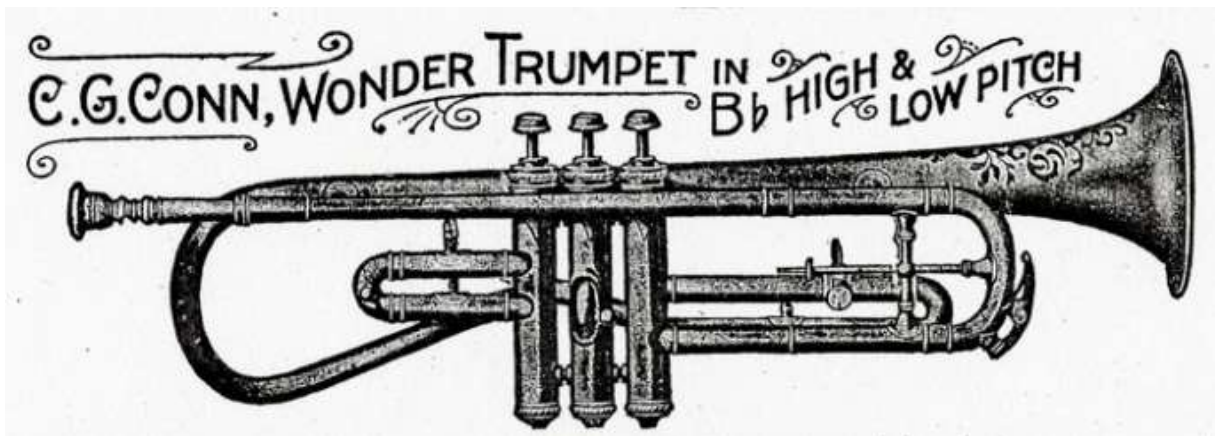

The 1906 catalog introduces the New Perfected Wonder Trumpet.  
Is this the first example of a slide trigger?

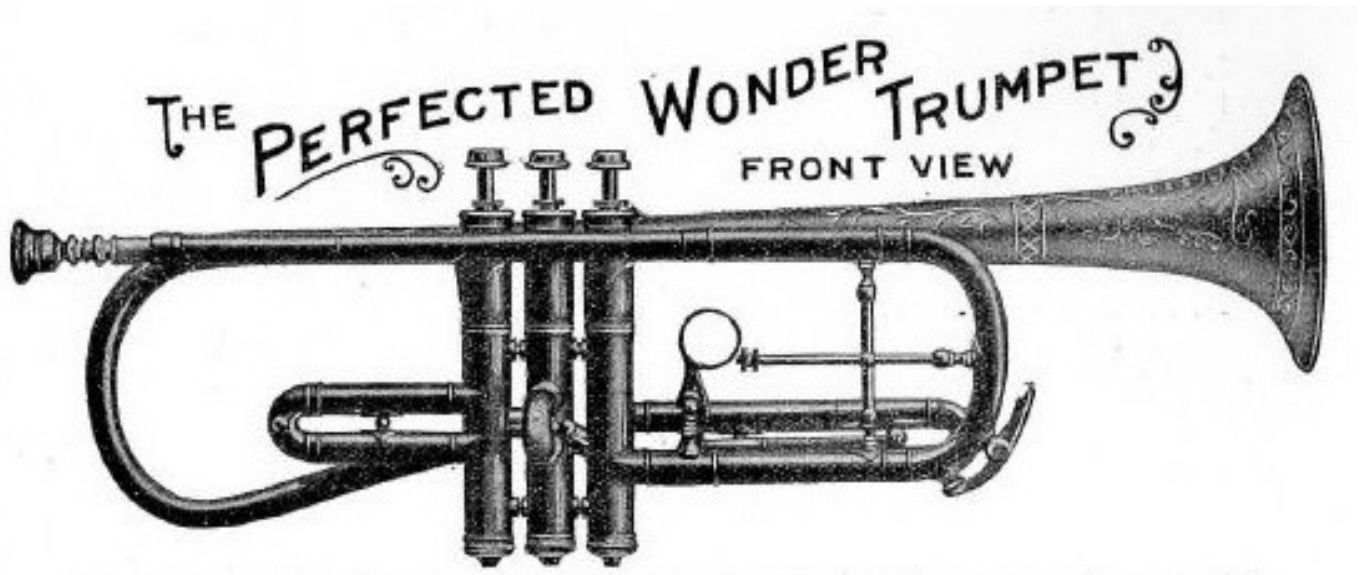



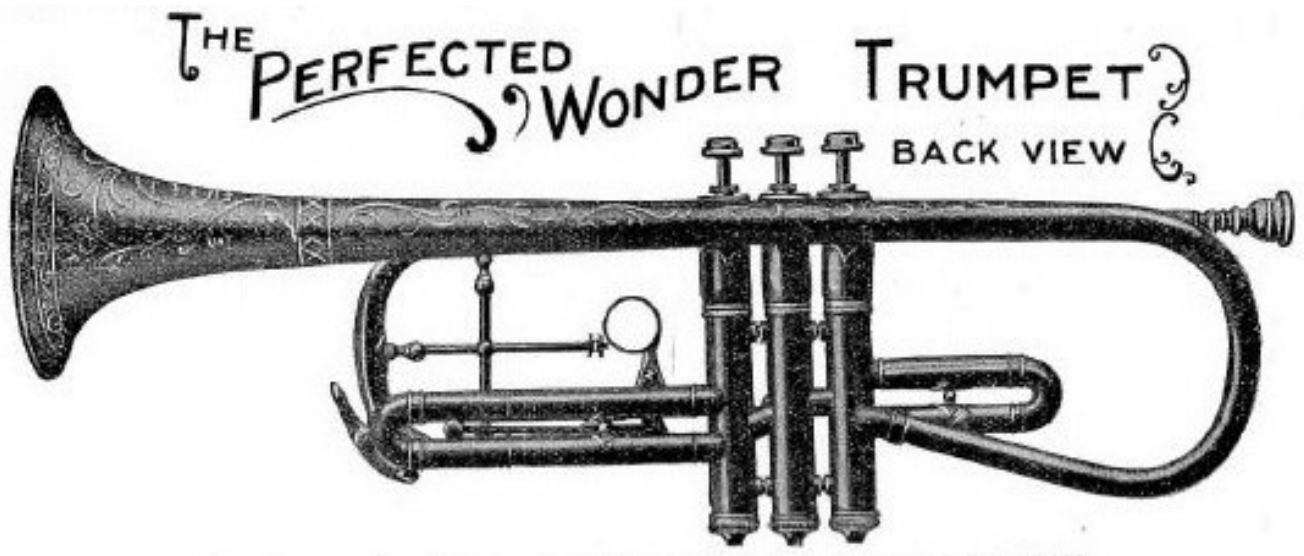

Perfected Wonder #92967 c.1906 (Emily K.)



Perfected Wonder #95363 c.1906 – now without the shepherd's crook



#97322 c. 1906 (Metzler Brass)



The Perfected Wonder is changed in 1909 with a new “S” slide brace and the slide stop moved.  
#107418 c.1909 (Metzler Brass)

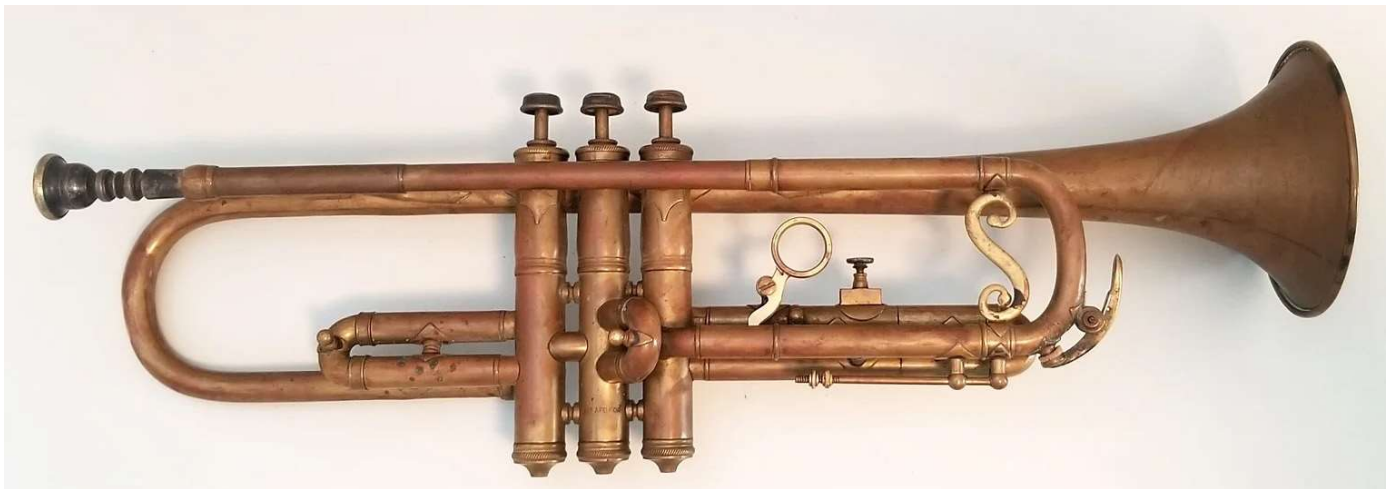

1910 Catalog image of the Perfected Wonder

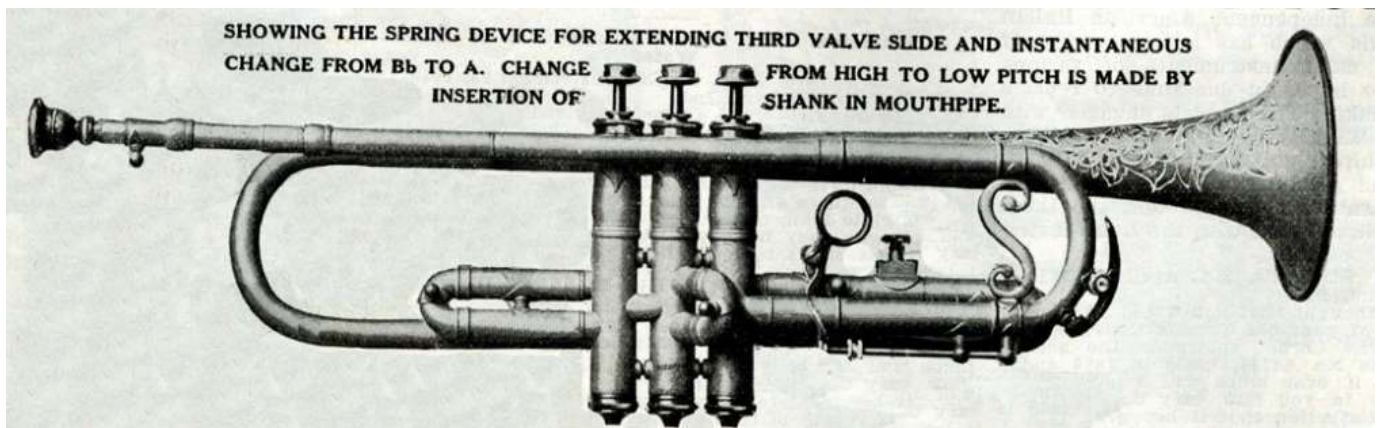



Symphony model Trumpet #116223 c.1910 (Metzler Brass)  
In the 1911 catalog this is called the "Latest Creation" and in 1912 the "Symphony".



This 1912 catalog image of the Symphony has the 3<sup>rd</sup> slide ring on top.

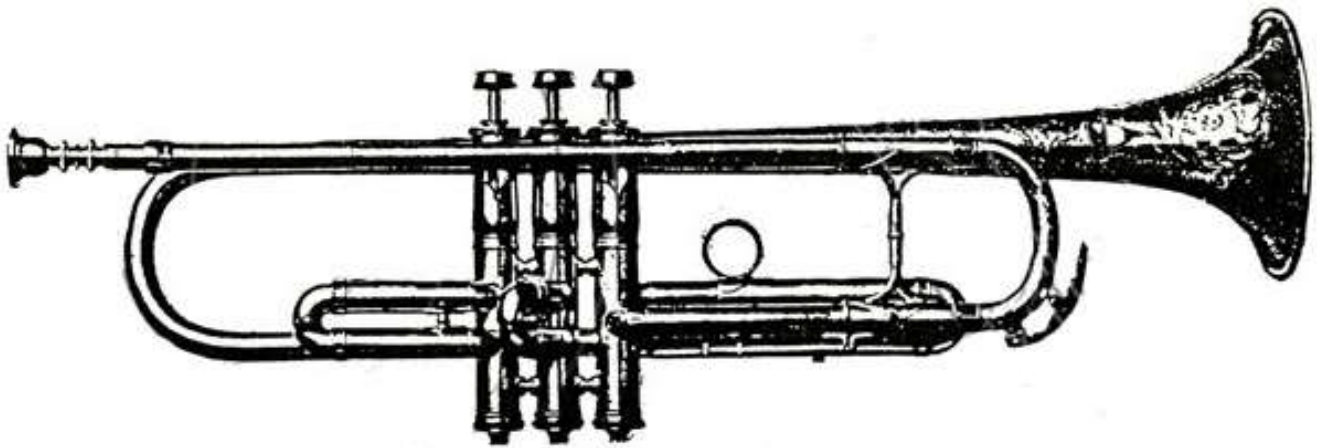

#126406 c.1912 in C/Bb/A (National Music Museum)



#127227 c.1912 in C/Bb/A (auction photo)



Two trumpet mouthpieces offered in 1913.

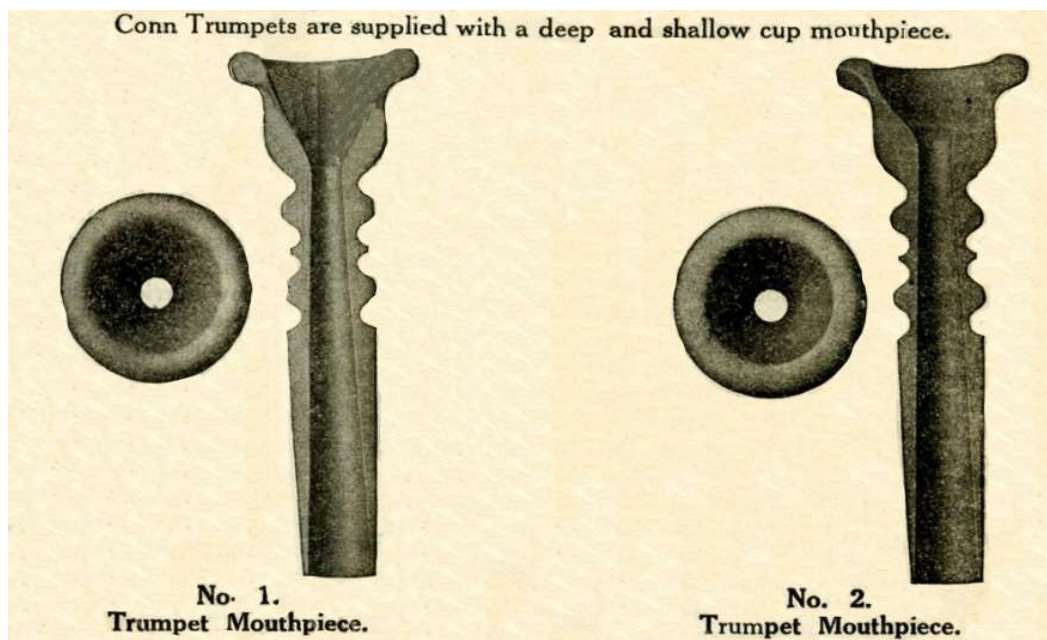

1913 Catalog image of the Symphony model.

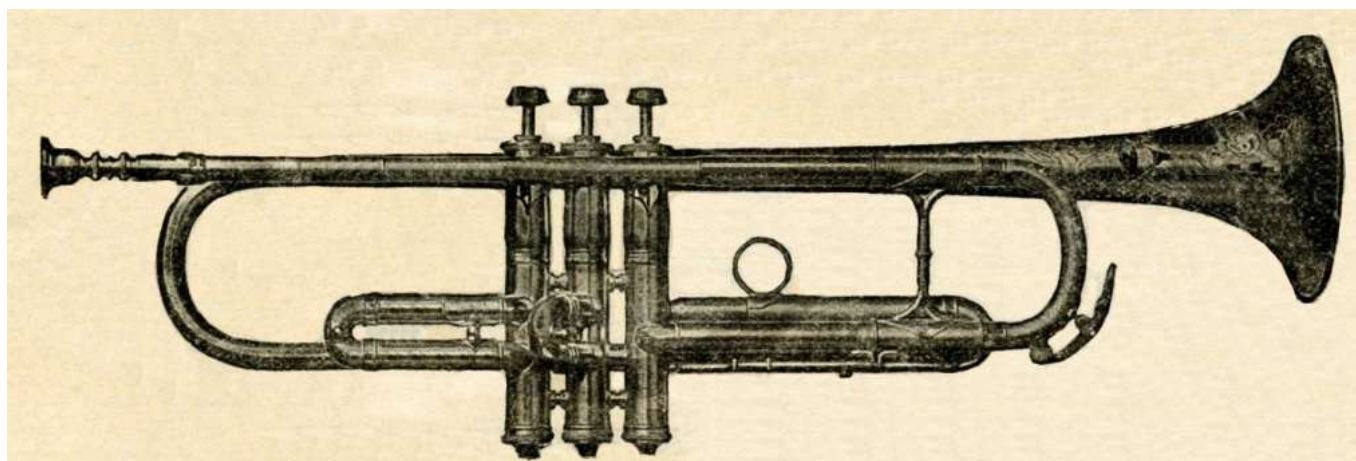



1914 New Symphony catalog image

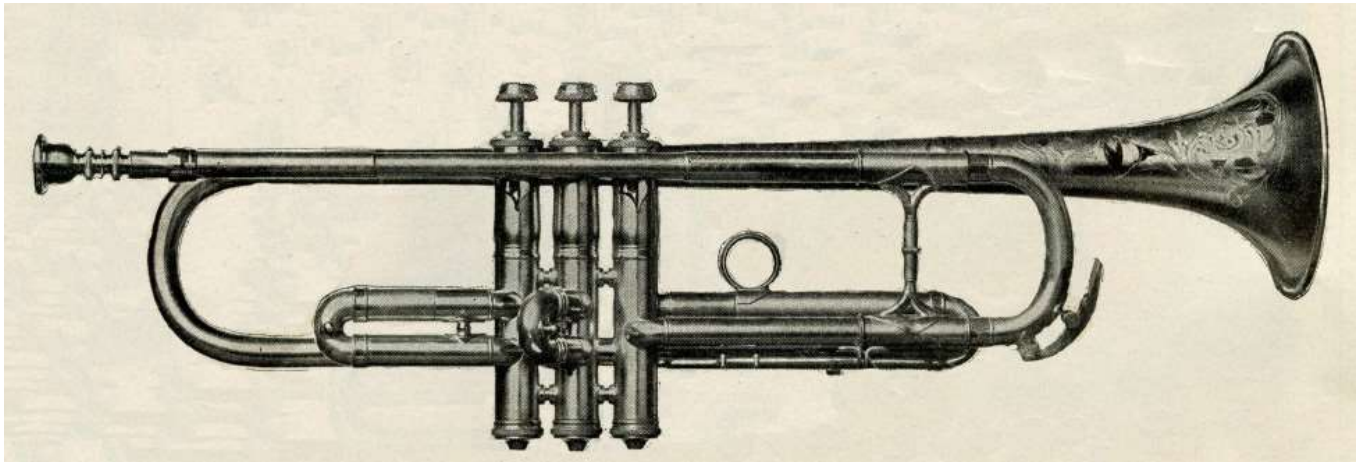

1916 Wonder Symphony catalog image (newly developed)

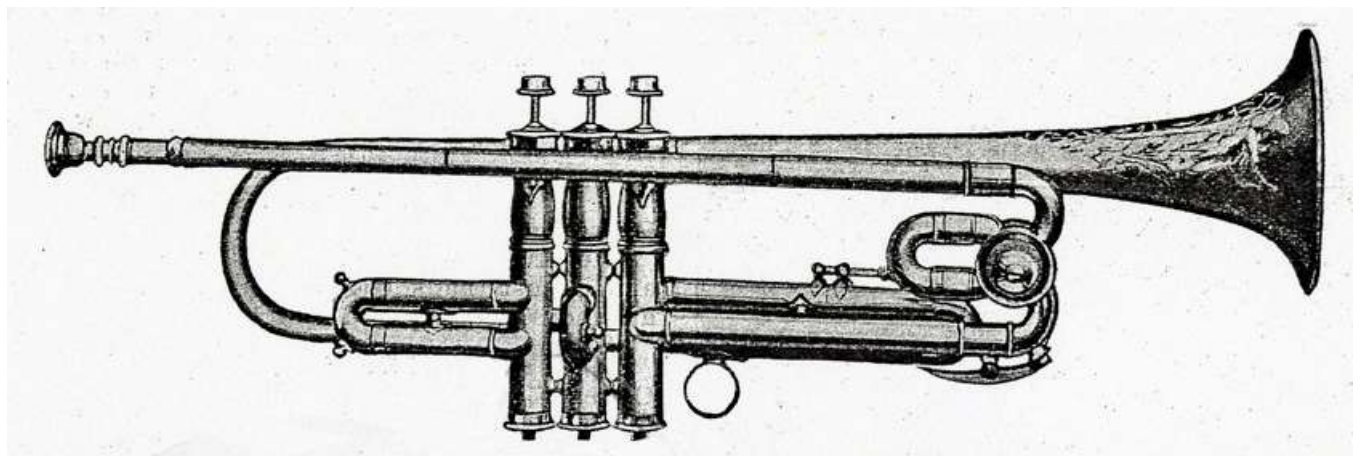

New Wonder #147815 c.1916 (National Music Museum)



1917 Wonder Symphony

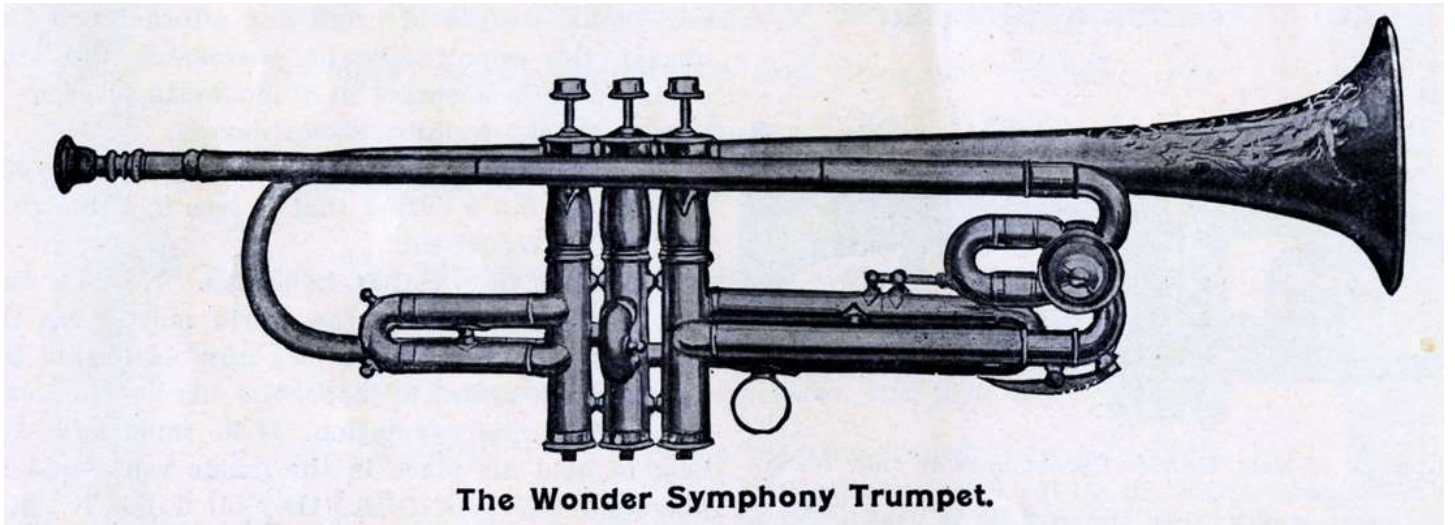

**The Wonder Symphony Trumpet.**

#160091 c.1918

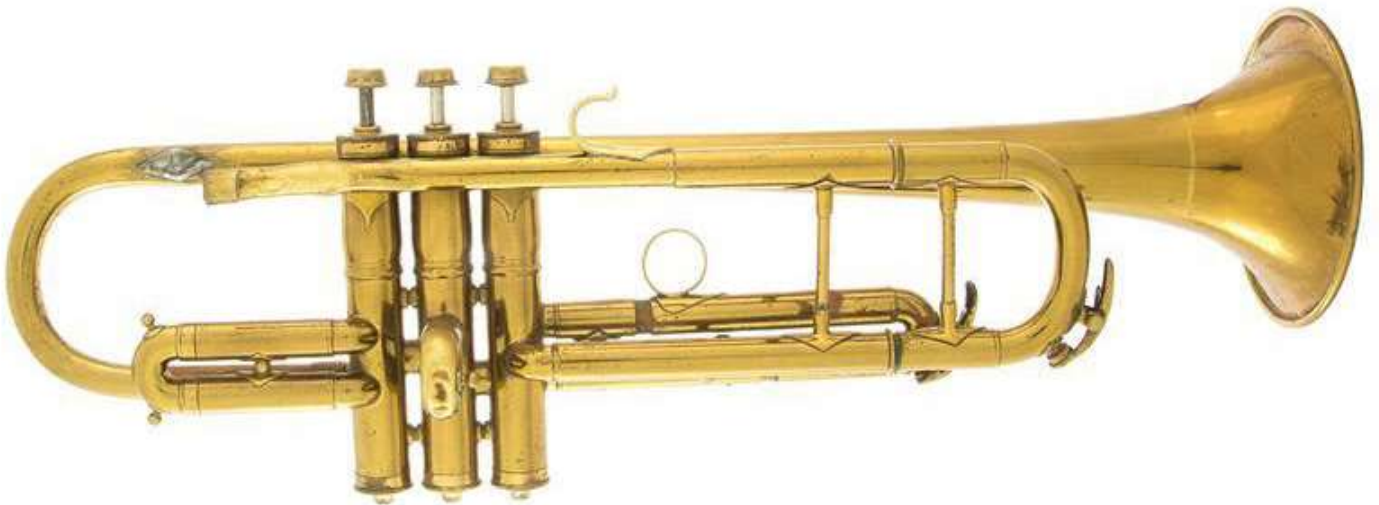

1919 New Wonder Symphony

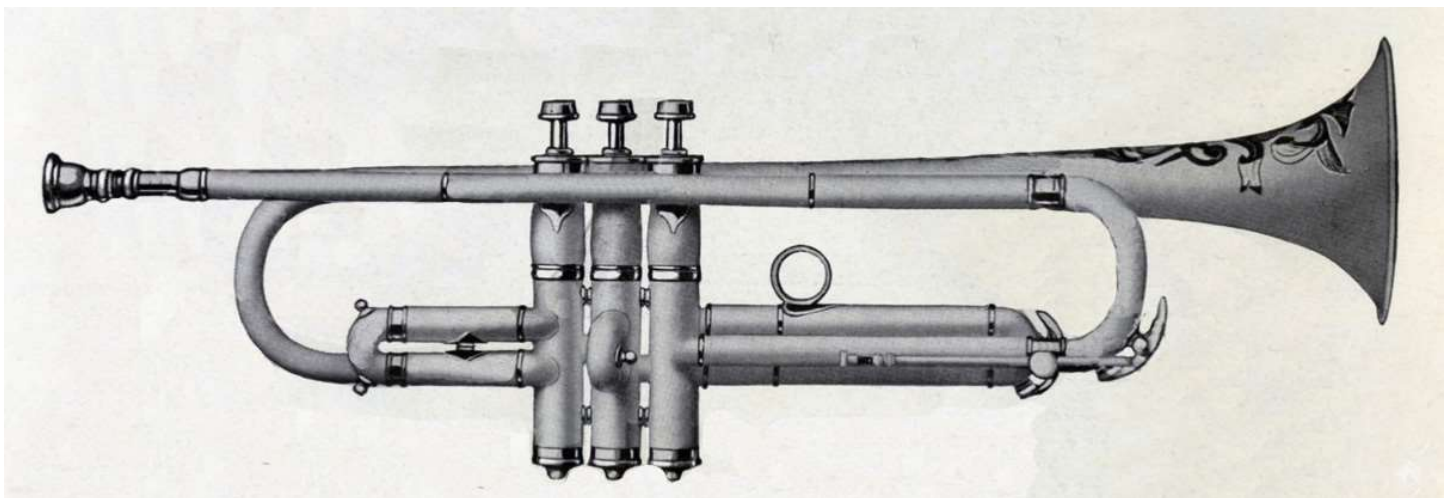



1919 New Wonder Rotary Bb/A

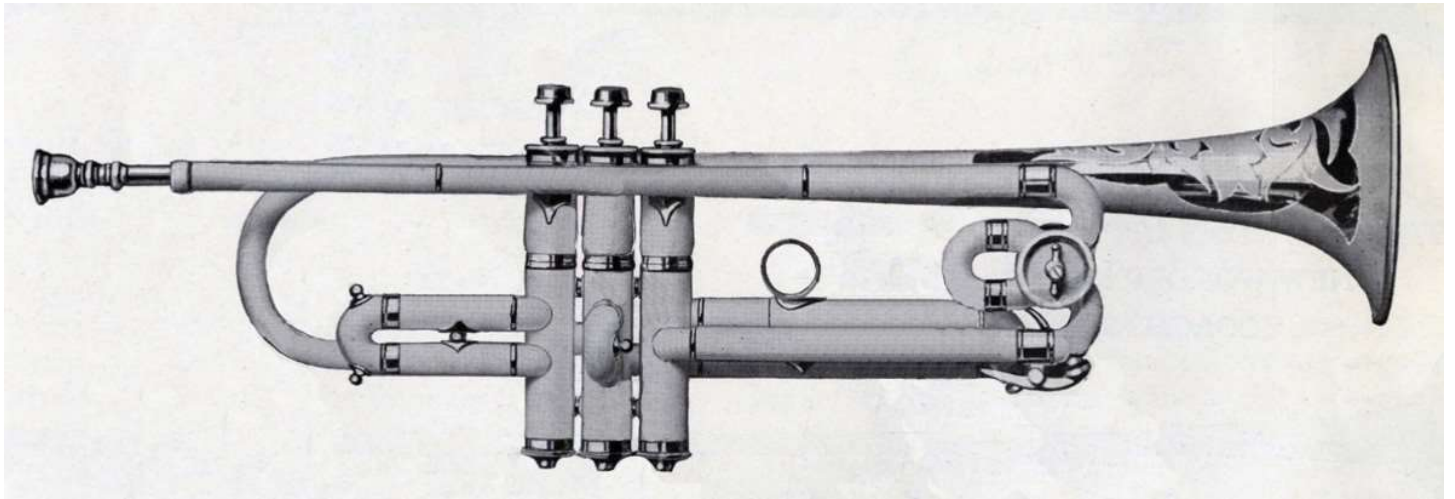

The 1921 catalog now offers the small-bore Opera Grand.

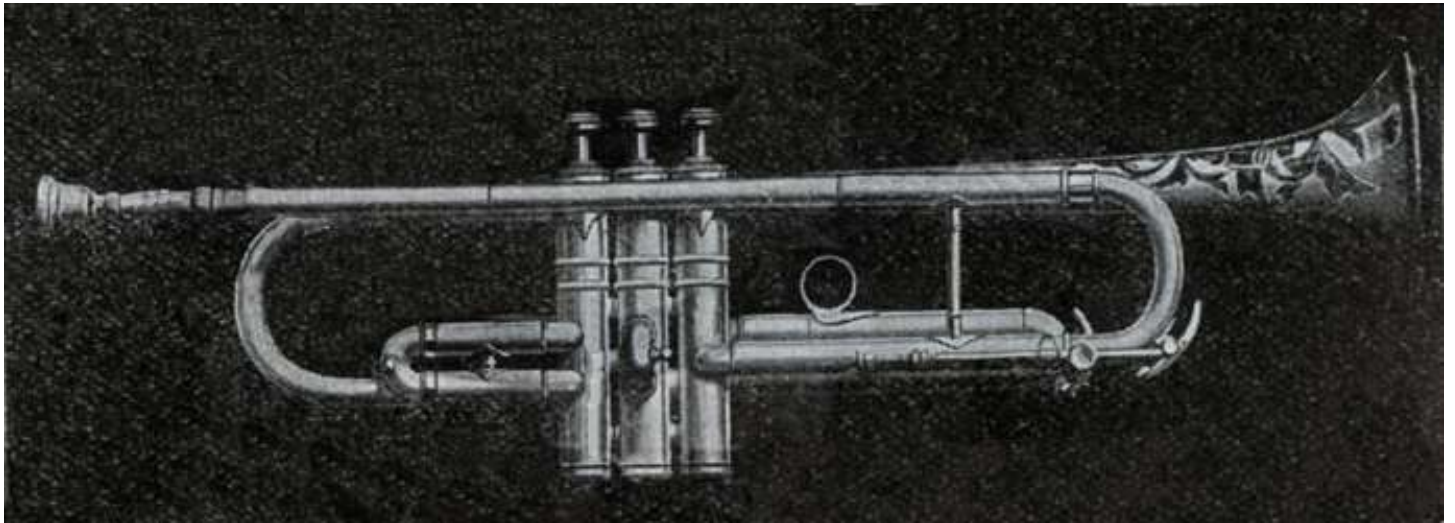

#185772 Opera Grand c.1921



#187323 c.1921



In 1922, the Symphony trumpet becomes the 22B.

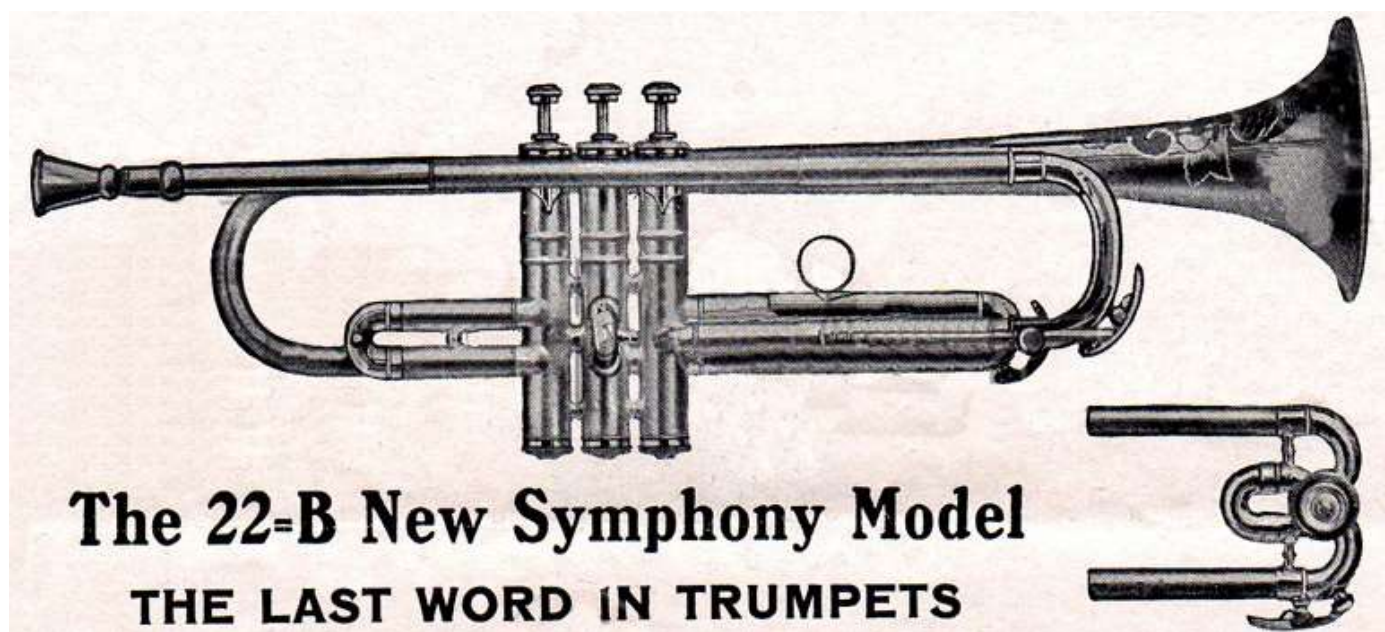

22B #193589 is the earliest one I have found so far (auction photo).





The 1923 catalog shows just the 22B.

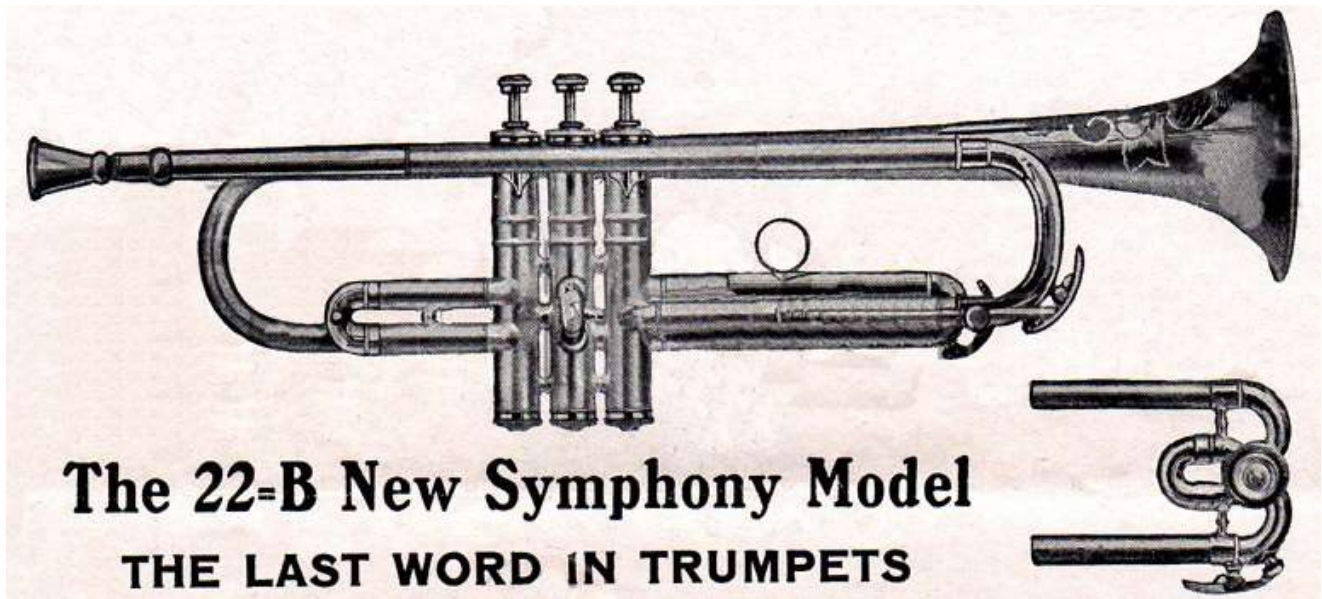

Conn Symphony mouthpiece c.1922 – a close match to these catalog images (author's photo).



## 1923 Model 16B Rosebrook Trumpet

- 1874 David Cobb Rosebrook is born in Portland, Maine on January 19 (WWI draft record).
- 1880 The Rosebrook family is living in Newport, Oregon. David's father is also a musician (census).
- 1893 David marries Marietta (census).
- 1894 Son Guy is born in Oregon (census).
- 1899 David Rosebrook, musician at Columbia Theater, rooms 247 Larkin (San Francisco City Directory).
- 1900 David C. Rosebrook, musician, 854 Hayer St, SF (census).
- 1910 David Rosebrook, studio musician, #470 10<sup>th</sup> St, Portland Oregon (census).
- 1911 David becomes the assistant principal trumpet in the SF Symphony Orchestra (stakowski.org).
- 1912 David is now the principal trumpet in the SF Symphony.
- 1916-1925 Cornet soloist with the Golden State Band (stakowski).
- 1918 David is a music instructor at the Alcazar Theater in SF (draft).
- 1919 Rosebrook ends with the SF Symphony. 1919-1925 He is the conductor for the Islam Shrine Band.
- 1920 Theater musical director, home at #5872 Ocean View, Oakland, CA (census).
- 1923 A Conn 16B trumpet has serial #200089 and is said to be the Rosebrook model (photo 2, Paul Ayick).
- 1926 He is featured in a Conn add and is said to play the Victor cornet and Symphony trumpet (Conn, photo 1).
- 1930 Symphony musician, #5872 Ocean View (census). He returns to the SF Symphony as second trumpet until 1934 (stakowski.org).
- 1932 Conn ad features Rosebrook as a west coast band leader and soloist who has played Conns for forty years. He currently uses a Victor 80A cornet (Conn).
- 1935 He begins as principle cornet soloist with the Goldman Band and plays for five weeks, then becomes ill and returns home (stakowski.org).
- 1937 David dies on March 31 in Oakland (CA record).

A few examples of this rare model have been found in the San Francisco area.





In 1924, Conn introduces an expanded offering of trumpets.  
Here is the 18B in C/Bb/A as shown set up for C. The 20B was only in C.

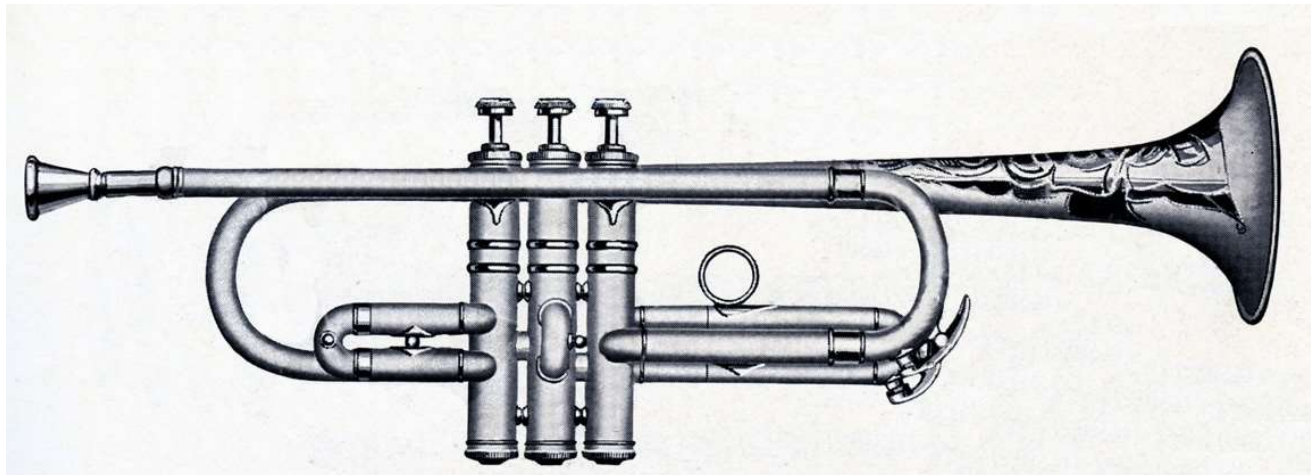

22B from 1924

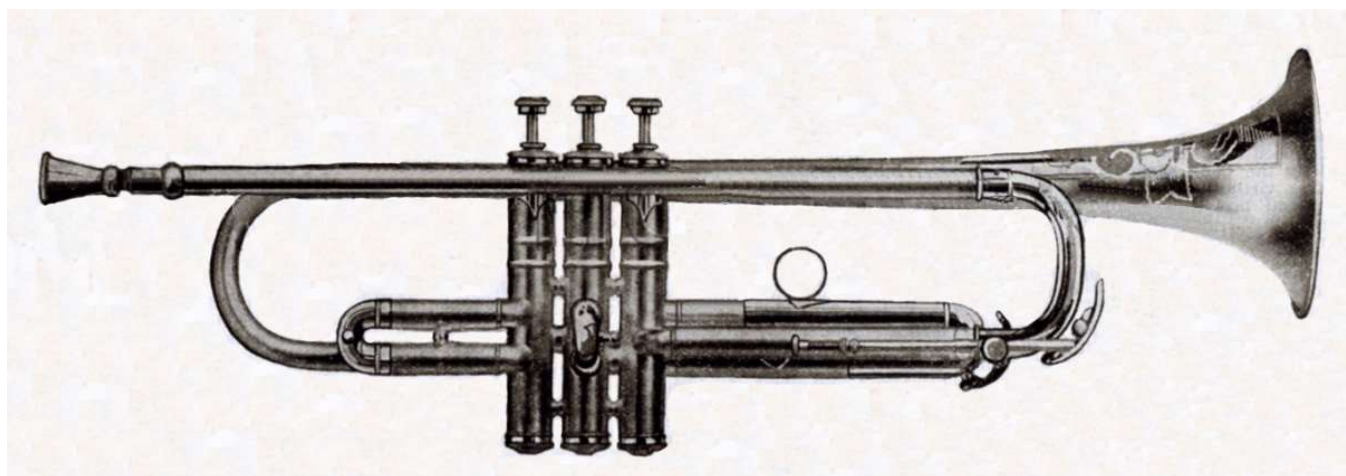

The other trumpets were:

Opera Grand in LP (24B) and HP (25B) – a 0.438” bore jazz model  
Medium Symphony in LP (26B) and HP (27B) – a 0.458” bore version of the 22B  
Concert Grand in LP (28B) and HP (29B) – a large 0.484” bore

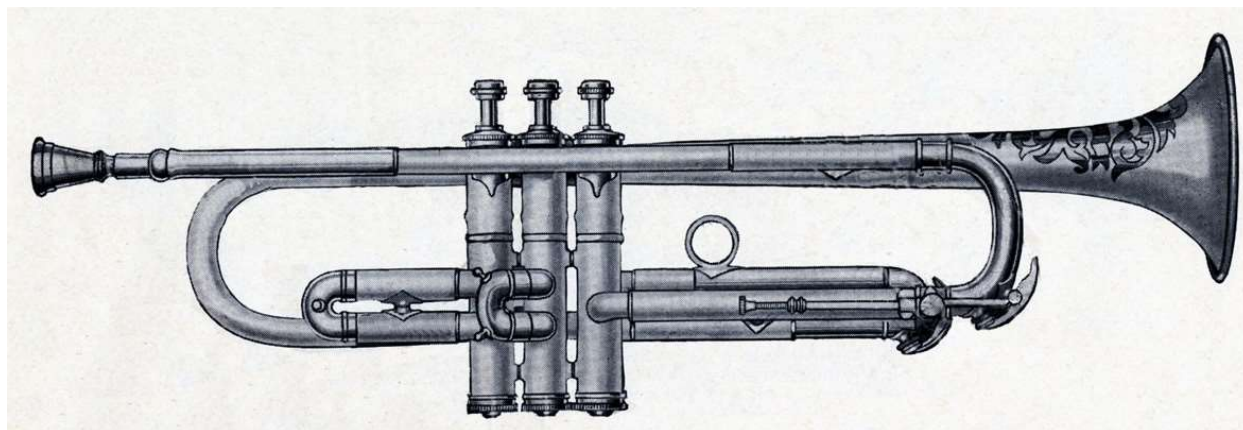

They are said to all be made with a one-piece bell using French brass.

They also offered the new Brilliance straight mute (author's photo).



22B #220969 from c.1925



18B #229564 from 1925 shown with Bb/A tuning slide.

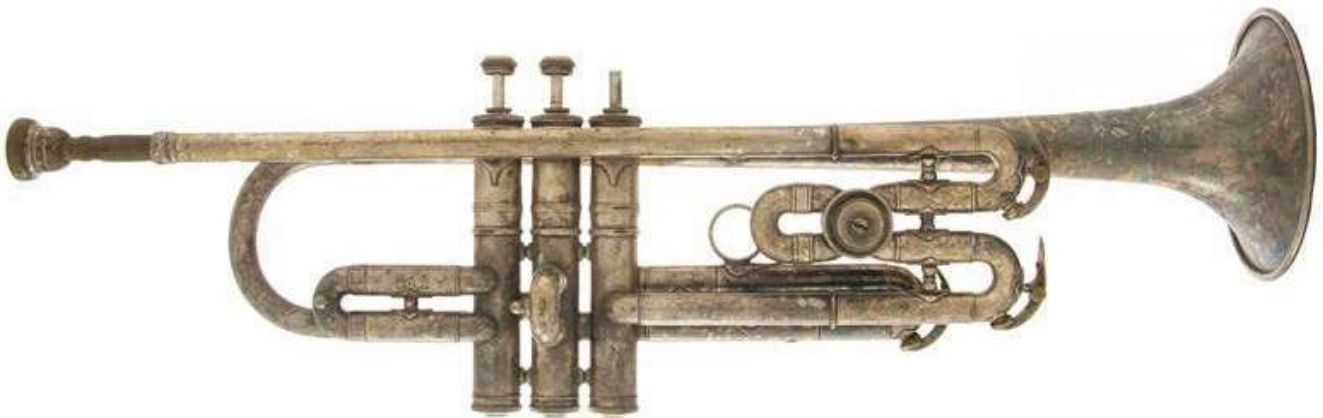



1926 model 18B in C/Bb/A

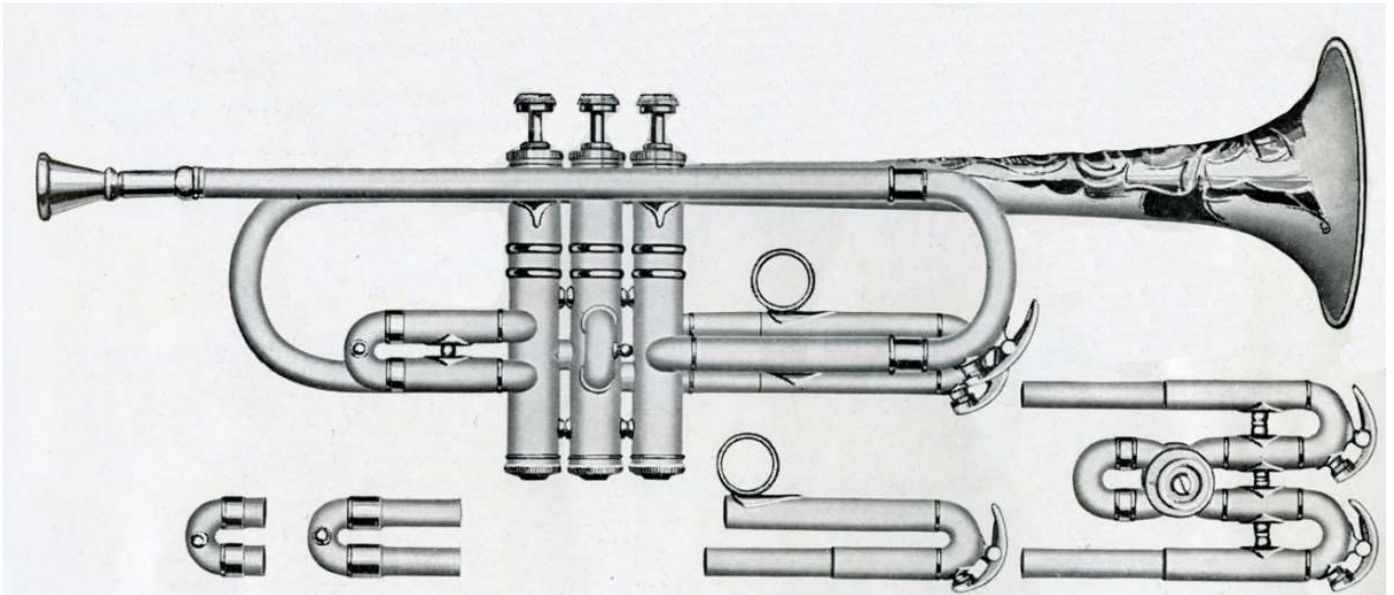

1926 model 22B New York Symphony

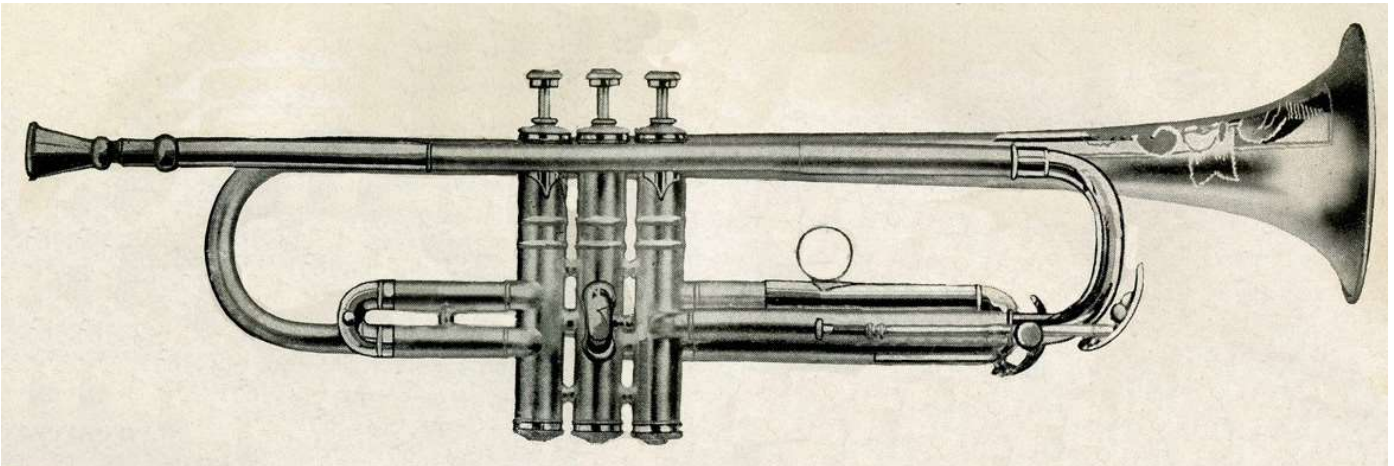

1926 model 24B Opera Grand

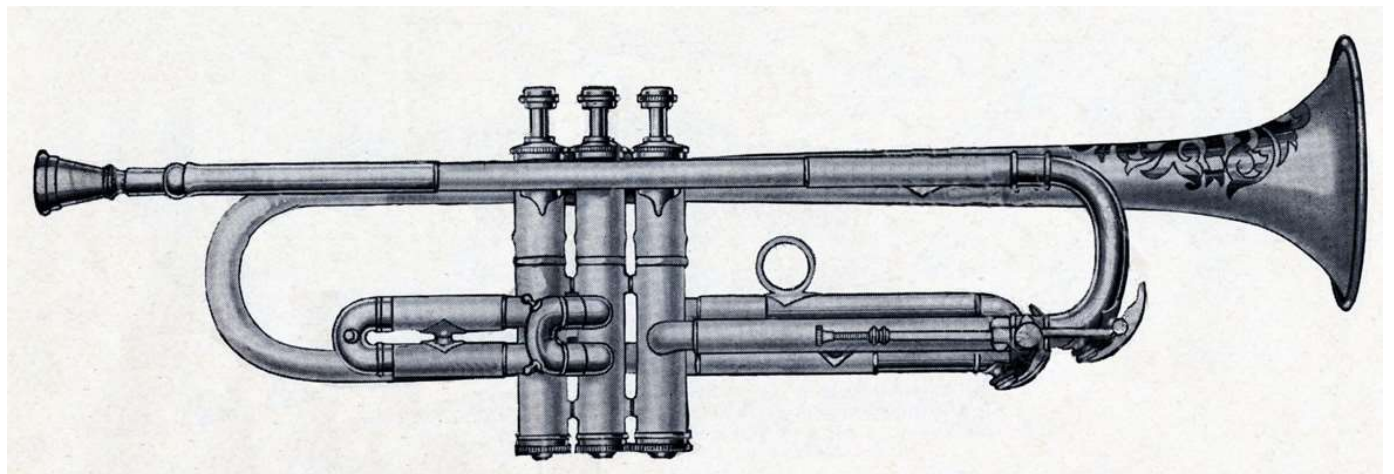

1926 Medium Symphony model 26B

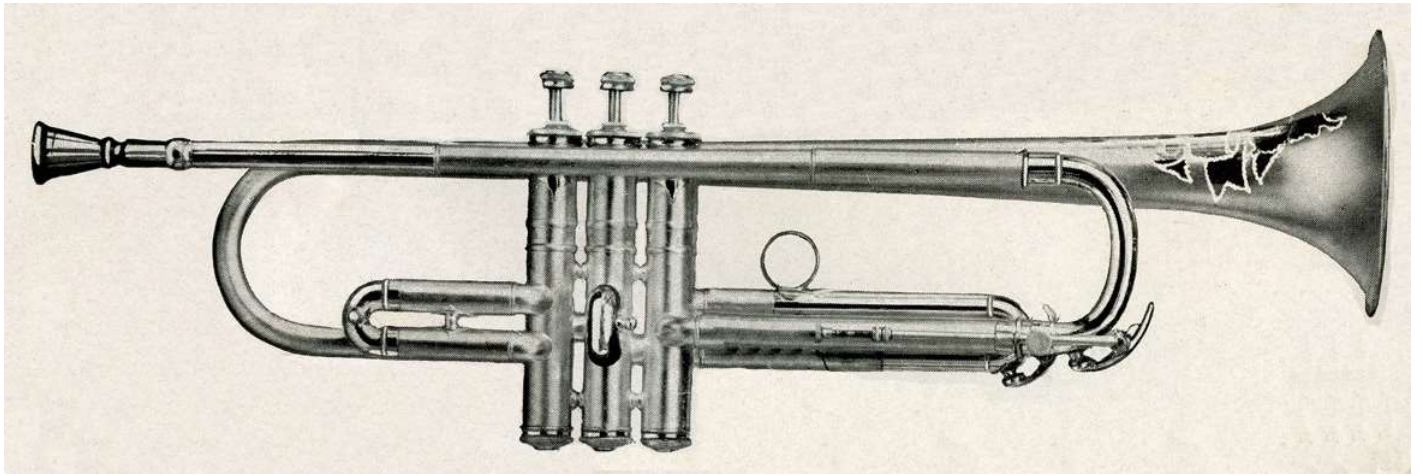

1926 Concert Grand model 28B

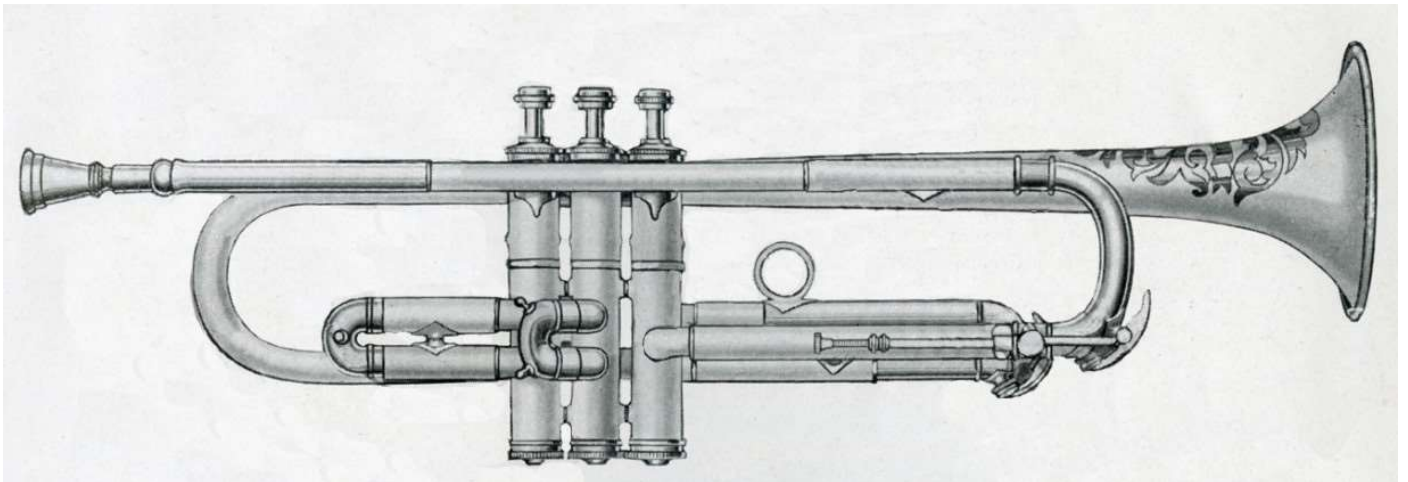

The new 1926 model 2B New World Symphony in medium 0.458" bore.

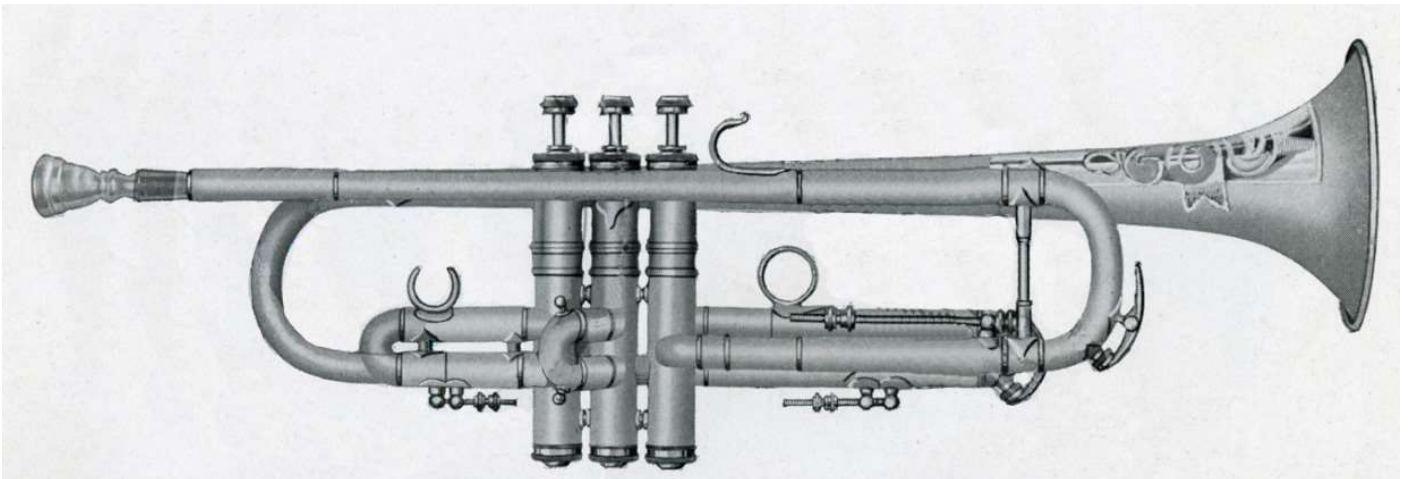



Model 26B #233825 c.1926



Model 26B #236653 c.1926 (author's photo)



Model 18B #237564 c.1926



The 1927 trumpets are the 2B, 18B, 22B, 24B, and 28B.  
They also introduce a new, patented mouthpiece with a plastic cup.

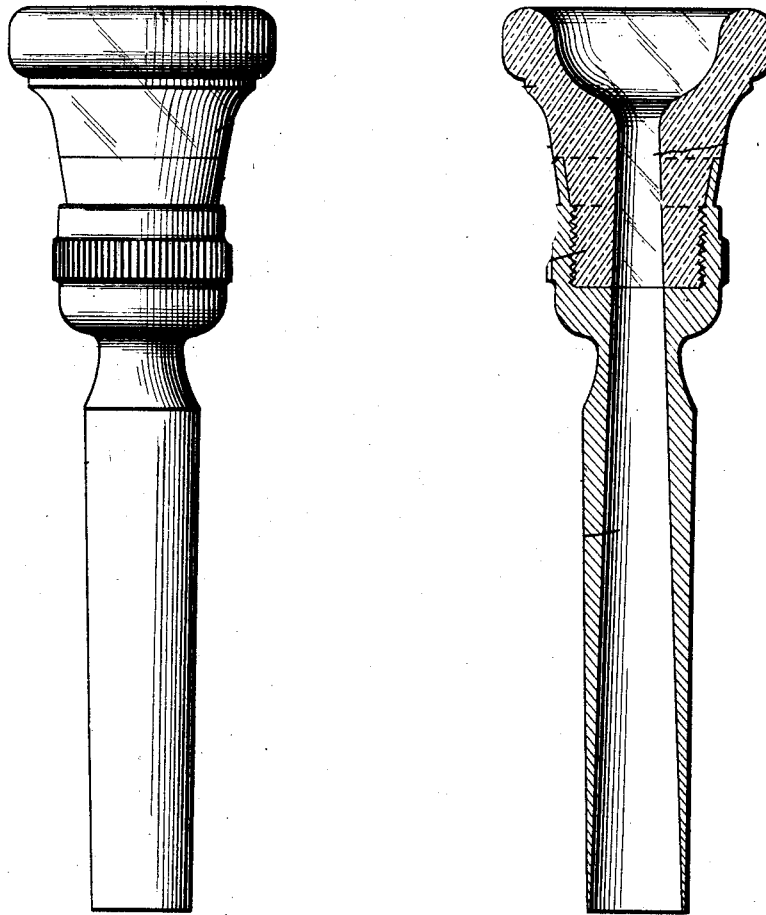

These were apparently quite popular as many are still found today.



1927 model 2B #242042 (National Music Museum)



1927 model 24B #250035



The 1928 models are 2B, 18B, 19B, 22B, 24B, 25B, 26B, 27B, 28B, & 29B.

They also introduce the New Era model trumpets in 56B, 58B, & 60B.

Conn claims to have been the first to make this slender design that becomes popular in the 1930s.

56 B from 1928 with Bb/A rotary valve and third slide trigger.

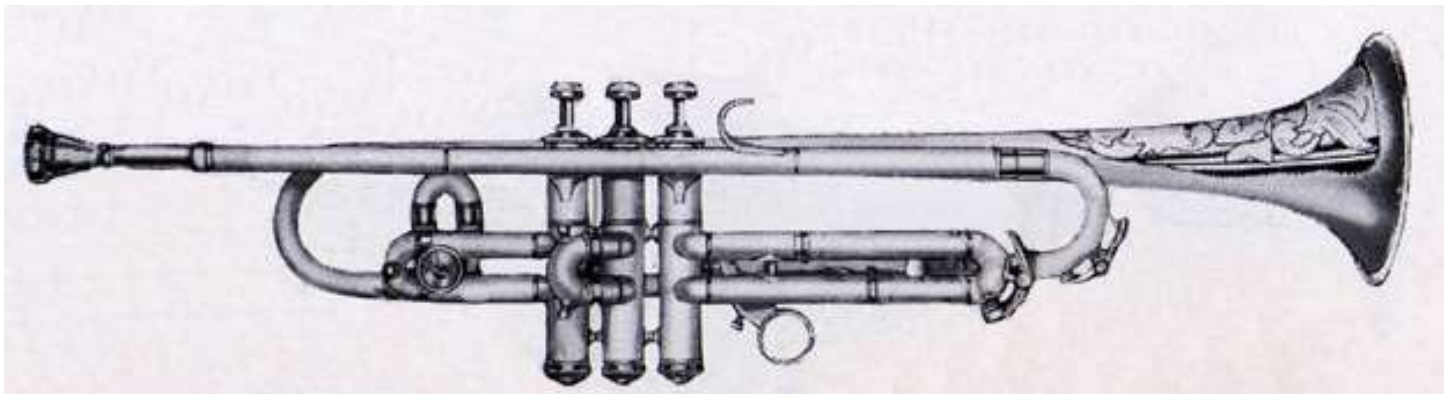

58B from 1928 without the rotary valve. These have the same small bore as the 22B.

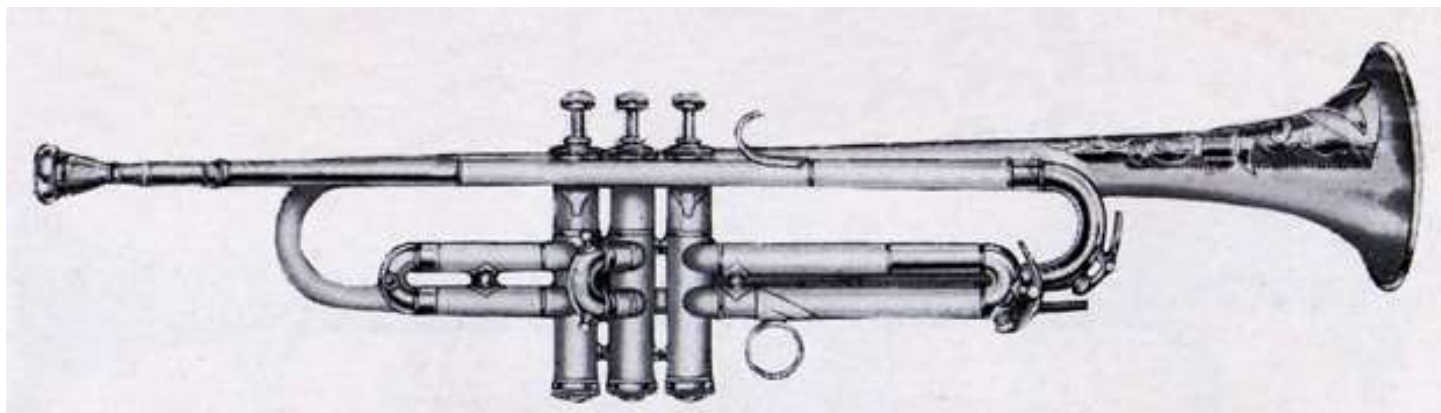

1928 model 18B #253608 (National Music Museum)



1928 model 2B #254604





1928 model 2B #257243 (author's photo)



1928 model 2B #260664 (auction photo)



1928 model 2B #260806 in gold plate (auction photo)





1929 model 58B #271661 in gold plate (auction photo)



1930 model 56B

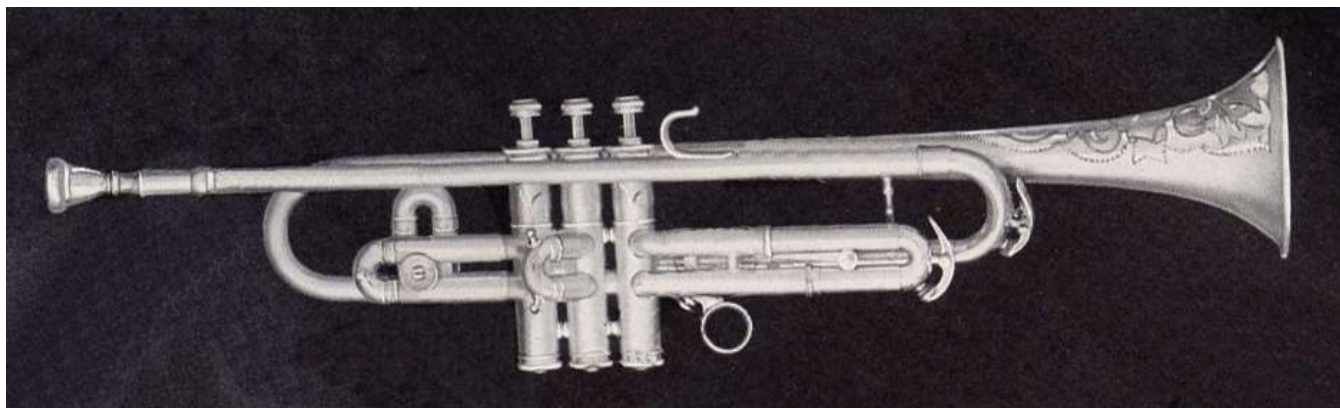

1930 model 58B

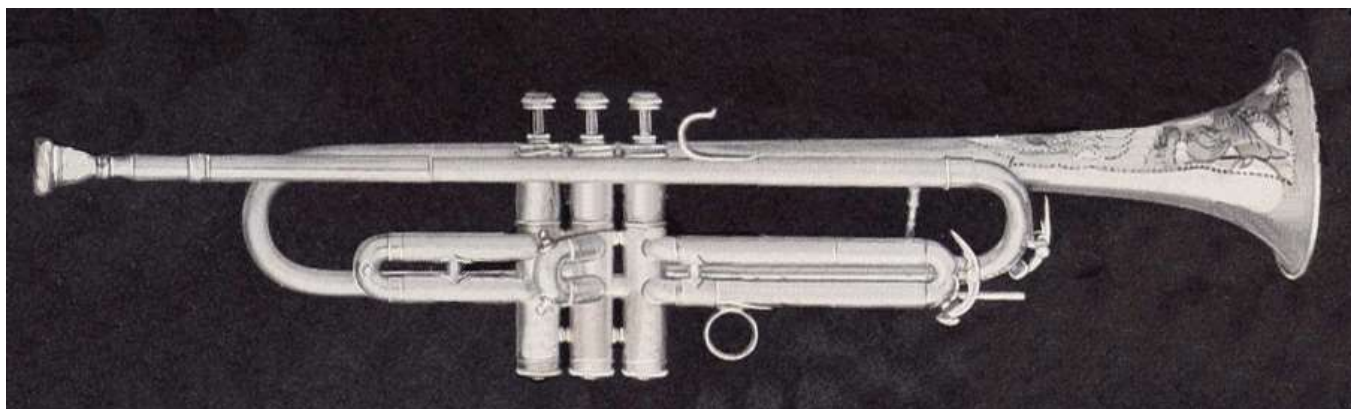

1930 model 60B #274916 (auction photo)





1930 model 2B #275484 (auction photo)



1930 model 58B #276001 in gold plate (auction photo)



1930 model 58B #278389 (auction photo)



The 1931 trumpets are 2B, 18B, 19B, 22B, 28B, 29B, 56B, 58B, & 60B (catalog).

1931 model 56B #280478



1931 was the last year that the 2B and 28B were advertised.

1931 model 2B

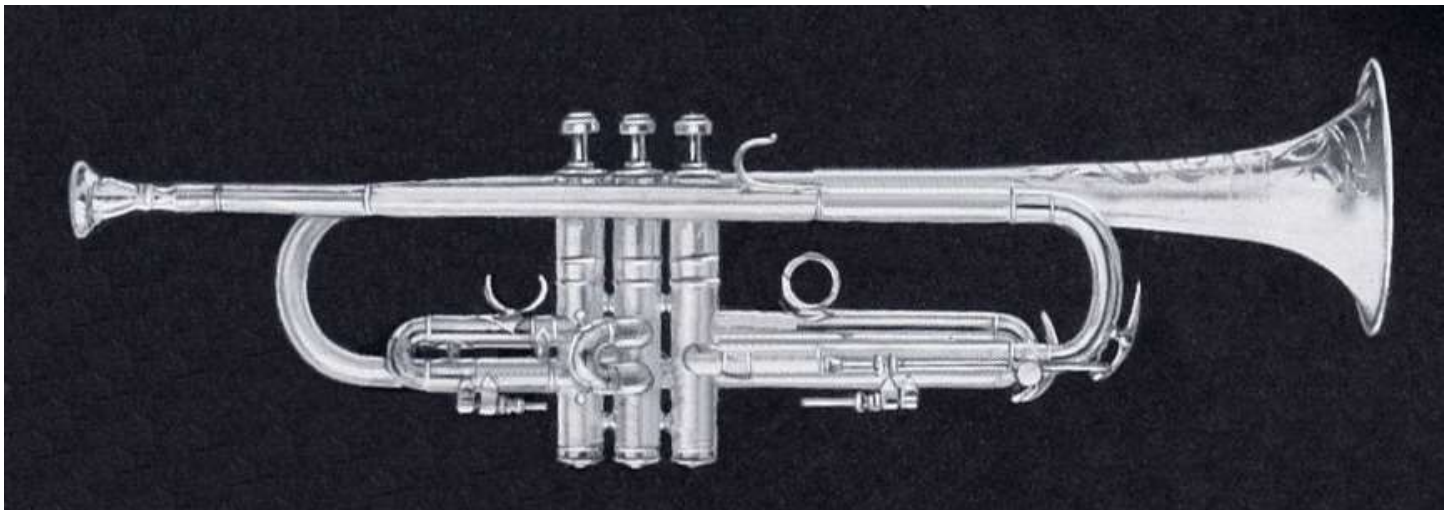

1931 model 22B

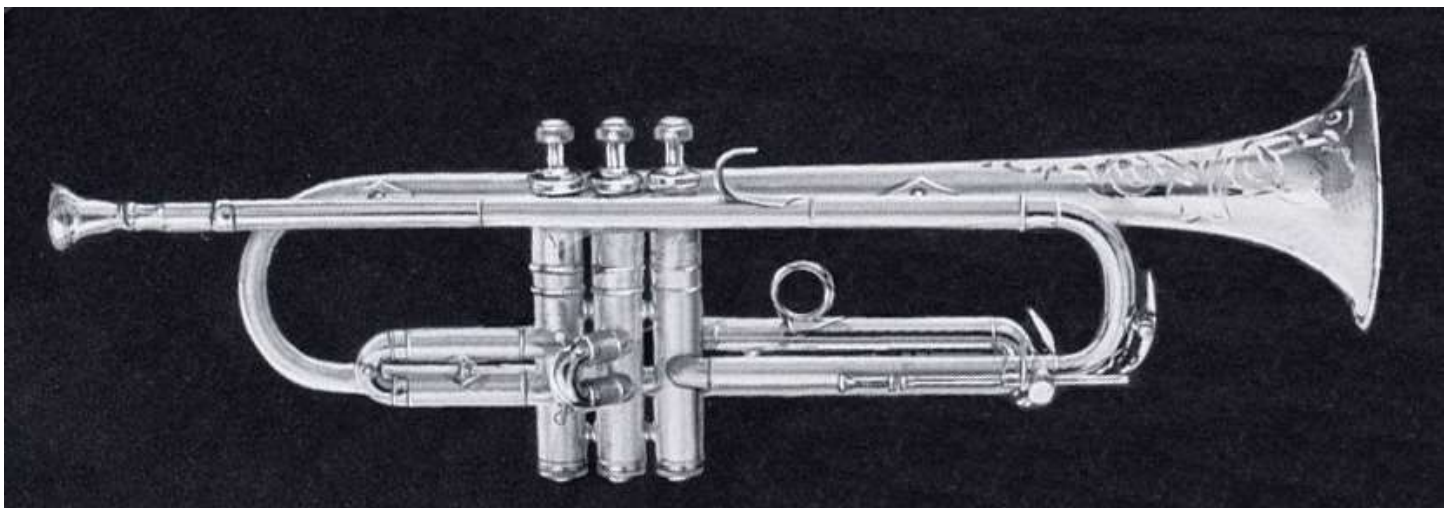



1932 starts the new Vocabell Connqueror model with a streamlined design.



1932 model 2b #281884 (auction photo)



# Harry “Hersch” Glantz

Ukraine – New York City - Florida

- 1896 Harry Glantz is born on January 1 in Proskurof, Ukraine, Russia to Pincus & Tillie Glantz (census & WWI draft).
- 1901 The family moves to New York City (passport application).
- 1909 Harry starts playing professionally (obit.)
- 1910 Living at #110 First St, Manhattan. Both Harry and father Pincus are musicians (census).
- 1917 Living at #859 Manida St, Bronx, musician with the Philadelphia Orchestra (WWI draft)
- Harry serves in the USMC from 12/14/17 to 12/19/18.
- 1920 Living at #859 Manida with his parents (census). He leaves for Europe on a tour with the New York Symphony Orchestra. He is 5’-8” tall with black hair and brown eyes (passport, photo 1).
- 1922 Harry marries Rae Fishberg in NYC.
- 1930 Living at #859 Manida, Bronx; orchestra musician (census).
- 1935 Conn advertises the Glantz model trumpet & cornet mouthpieces (Conn catalog).



- 1936 Conn advertises the Harry Glantz 18B trumpet in Bb and 14B trumpet in C (Conn catalog).
- 1940 Orchestra musician, #859 Manida (census).
- 1950 Radio musician (NBC), 122C West End Ave, Manhattan (census).
- 1958 Harry moves to Florida (obit.).
- 1972 Harry is appointed to the University of Miami Graduate School of Music (obit.).
- 1989 Harry dies on December 18 in Bay Harbor, Florida (obit.).





Conn introduces the Clickless Crysteel valves with bottom springs.

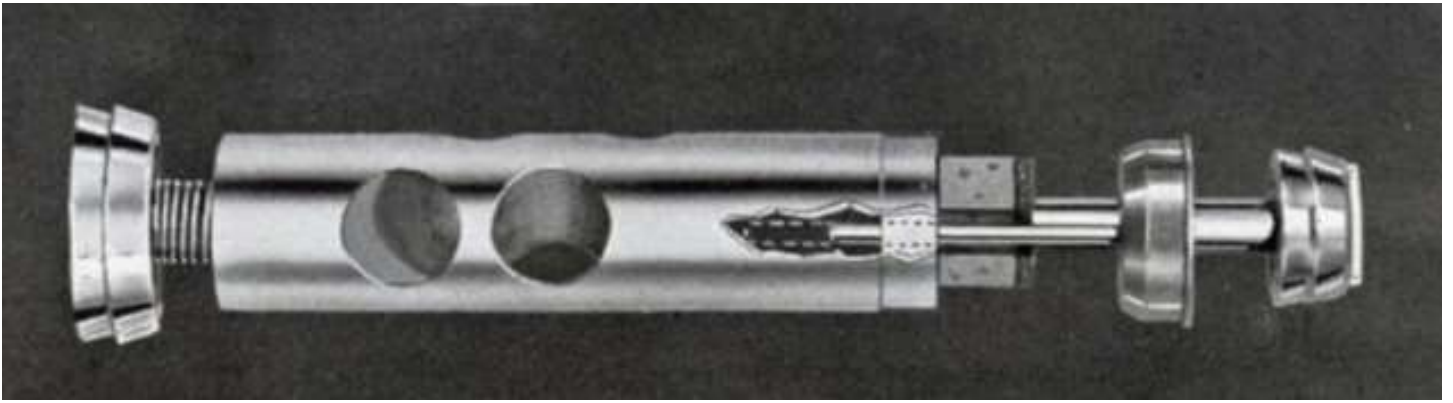

1934 14B Harry Glantz model in C #300220 (auction photo)



1934 model 8B



8B  
SYMPHONY GRAND  
TRUMPET



1934 model 40B Vocabell

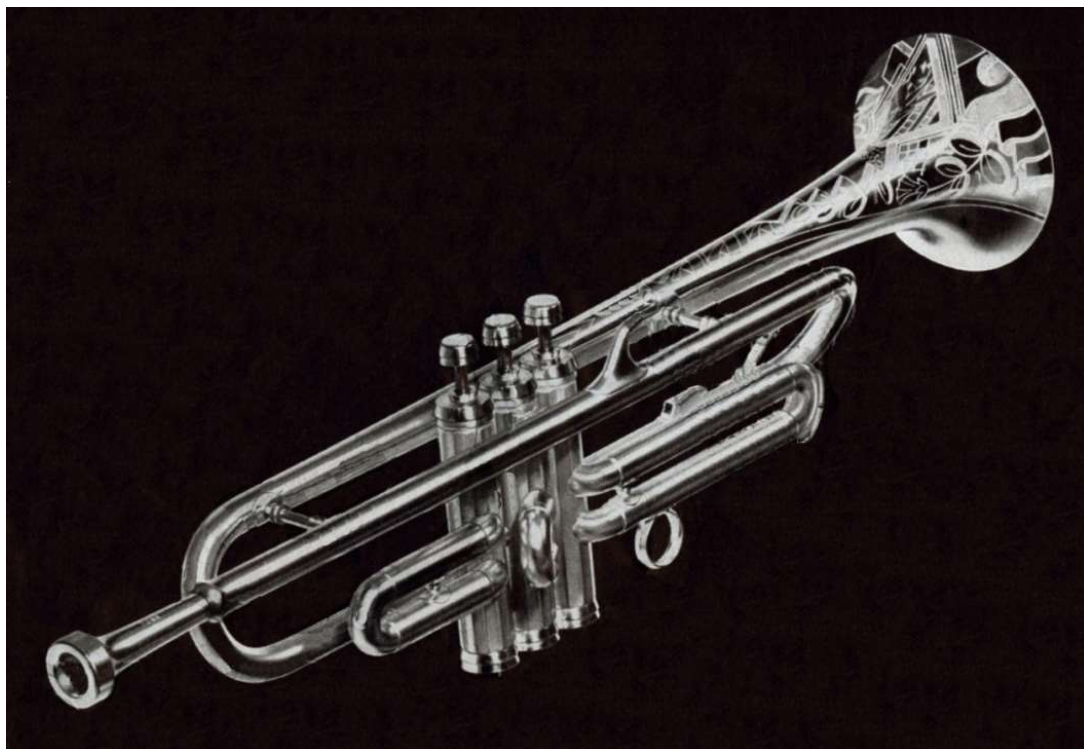

1935 model 40B Vocabell #300972 (auction photo)



1935 model 40B #302118 (auction photo)





# Joseph Gustat

## Illinois – Denver – St Louis - Orlando

- 1888 Joseph Gustat is born on March 9 in Coal City, Illinois to Italian immigrant parents (census & WWI draft).
- 1907 Joseph marries Margaret Bischof in Pinckneyville, Illinois.
- 1910 They are living at #1241 Cherokee St in Denver and he is working as a theatre musician (census).
- 1917 They are living at 1769 Logan St, Denver, and he is a cornetist at the Empress Theatre (WWI draft, photo 1).
- 1920 Joseph starts as first chair trumpet in the St Louis Symphony (stokowski.org).
- 1930 Home at #3738 Lindell Blvd in St Louis and working as a symphony musician (census).
- 1935 Conn advertising has Gustat playing the model 8B Symphony Grand trumpet.



- 1936 Gustat switches to second trumpet at the St Louis Symphony under Samuel Krauss (stokowski.org).
- 1940 Living in Richmond Heights and working as an orchestra musician (census).
- 1947 Gustat ends with the St Louis Symphony (obit.).
- 1950 Now living at 1500 Ridgewood in Orlando, FL (census).
- 1951 He dies on 11/13/51 in Orlando and is buried in Pinckneyville, Illinois (Find-a-grave).



The new 1935 New York Symphony Special #302218.

This was a 22B with added nickel silver tubing and engraving back to the rear bell brace.



1936 New York Symphony Special #309968 (auction photo)



1936 model 22B #310000 (auction photo)





1936 New York Symphony Special #313622 (author's photo)



1937 model 8B Symphony Grand





1937 model 8B #317732 (auction photo)



1937 model 12B #321377 (auction photo)

This was a new model with the Coprion copper bell.



Starting in 1937, all mouthpieces had this newer design in five sizes.

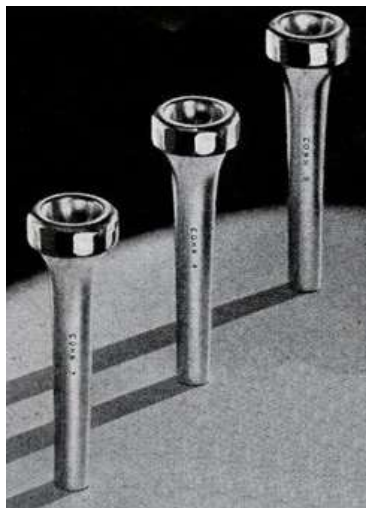



The 1938 trumpets were 8B, 10B, 12B, 14B, 18B, 22B, 40B, 48B, & 58B.

1938 Symphony Grand 8B



1938 10B in medium bore or 58B in small bore



1938 12B with seamless Coprion bell

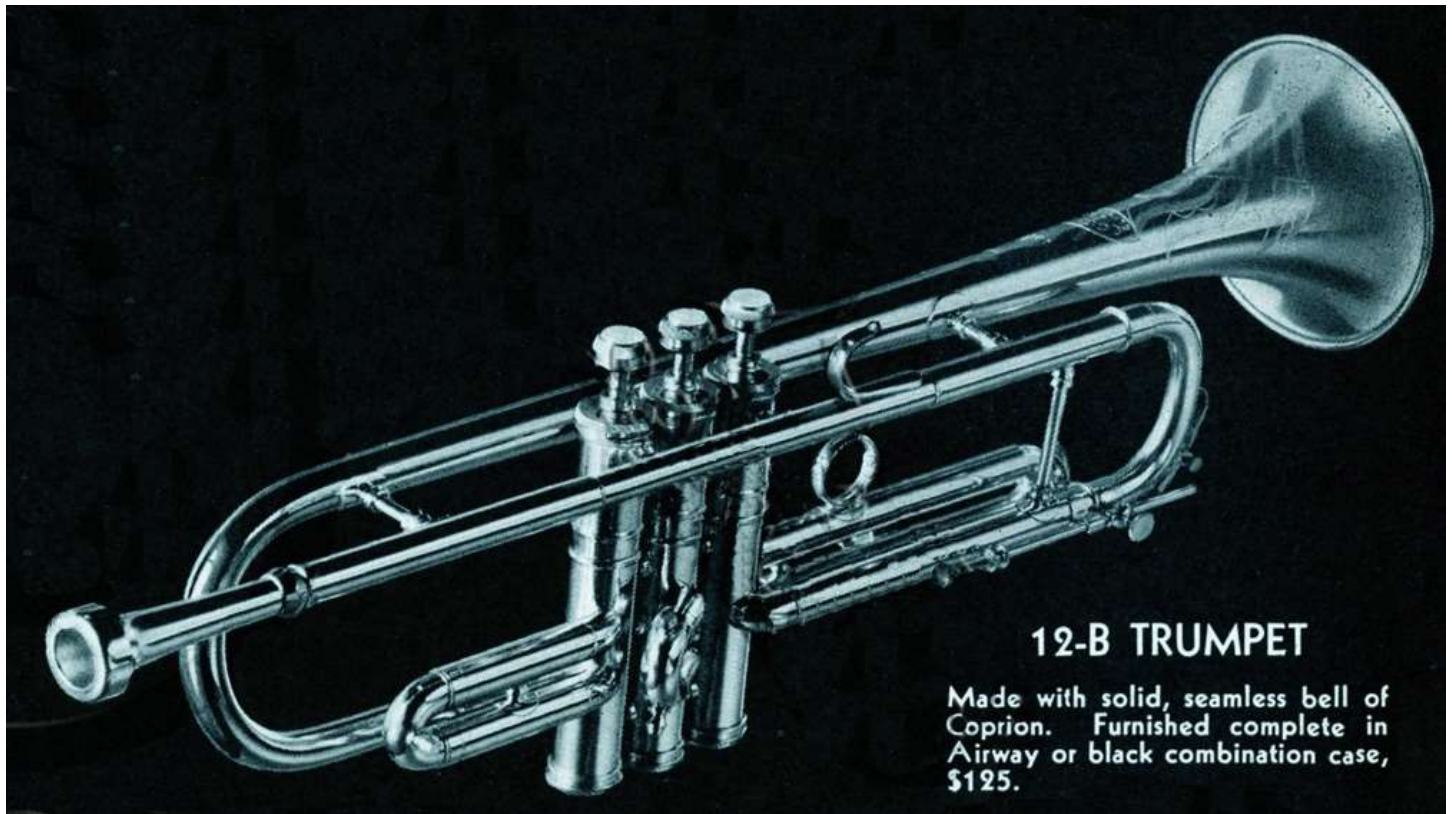

1938 medium bore 48B





The 1940 trumpets include the 8B, 10B, 12B, 22B, 40B, & 48B.

In 1941, Conn introduces the return of the 2B due to demand.

n



1940 model 2B #336006 (auction photo)



1941 model 12B #343043 (auction photo)



1942 New York Symphony Special #349607 (author's photo)



Typical case from this period.

*Below is shown the combination trumpet case. The combination case for cornet is similar. Blocking which holds instrument is hinged at back so it can be raised to carry music and accessories. Silk plush lining, Keratol covered. Trombone case of this design, Keratol covered, and lined with silk plush.*





Case for #349607 (author's photos)





## 1942 Registry Card

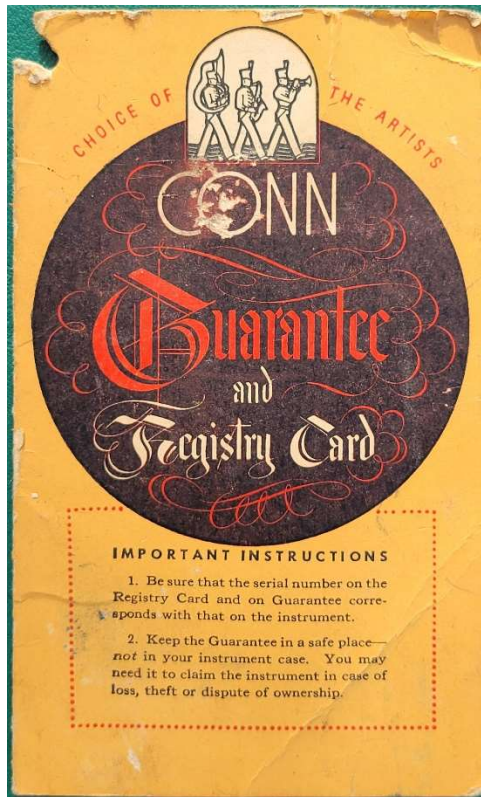

### FREE BOOK—MAIL THE CARD

For best performance it is necessary for you to know how to take care of your instrument. Upon receipt of your Registry Card, Conn will send you free a 40-page book entitled "How to Care for Your Instrument." The information in this book is authoritative, comprising the cumulative knowledge and experience of band instrument designers, repair men and professional musicians.

*In no other single book can you find such valuable and helpful information.* For example:

1. What extra precaution should valve instrument players take after a parade or outdoor concert?
2. What is a quick, easy way to tighten a clarinet tenon or bell ring?
3. How can you prolong the life of saxophone pads?
4. Should piston be used to lap out a dent in the casing? Why?
5. Do you know how to wrap a cleaning rod properly?
6. Should a key instrument be laid on its side during a playing engagement? Why?
7. What are two precautions every clarinet and oboe player should take to avoid broken tenons?
8. Should brass instruments be stored near the furnace room? Why?
9. How can you oil a French Horn rotary valve without taking it apart?
10. What are the standard meanings of the following: knuckle, crook, port, venturi, spatule, ligature, bit, stocking, baluster?

In this book you'll find answers to these and hundreds of other questions on instrument care. Packed with illustrations.

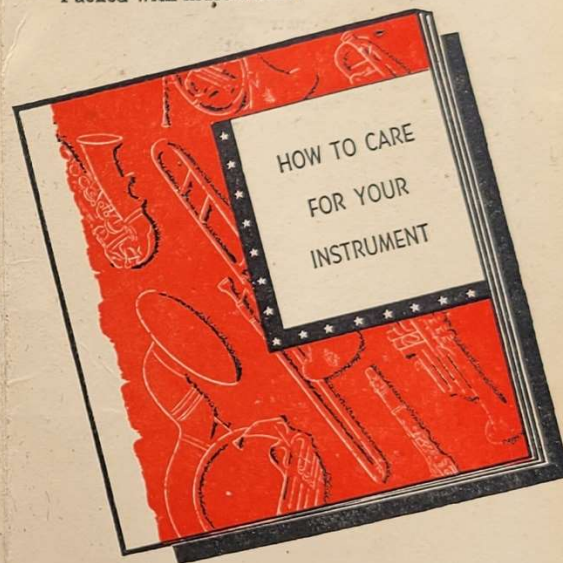

*When you get the book you will know that your instrument is registered and your Guarantee is in effect.*

**DON'T DELAY - MAIL TODAY**

160-6X-LEG-D-RK-SPC  
PRINTED IN U. S. A.



## 1942 Lacquer Card

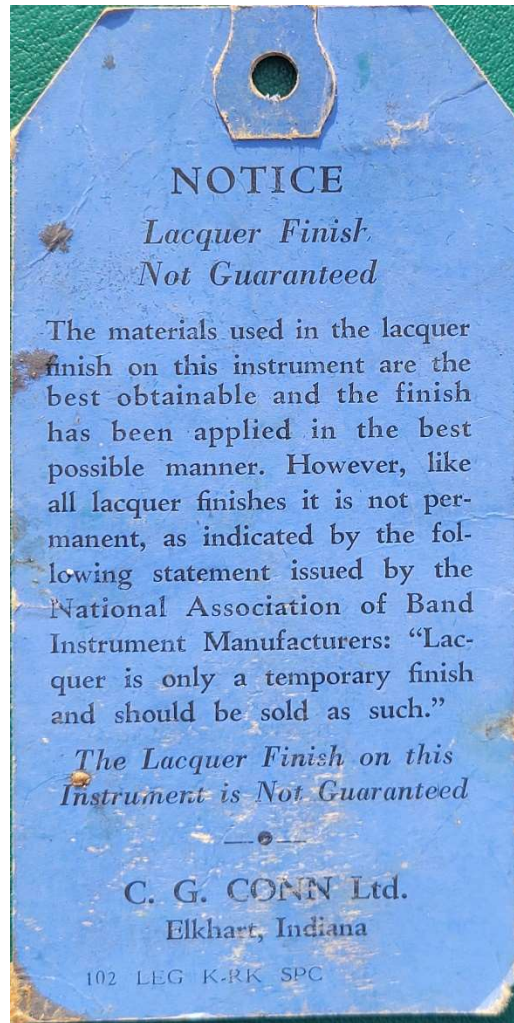

1941 New York Symphony Special (This model ends with WWII.)



Conn engraving from 1930 model 58B.

